

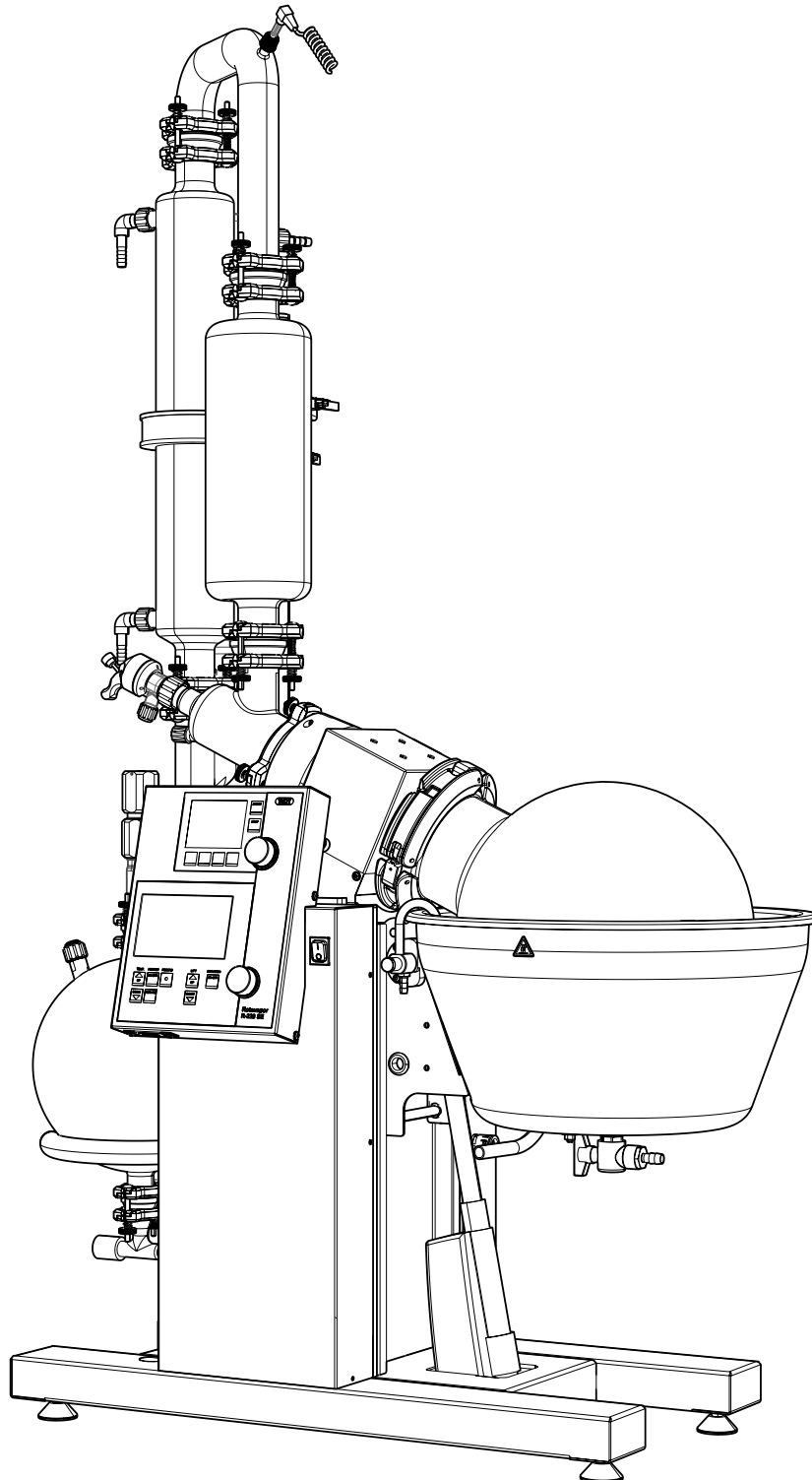

Rotavapor® R-220 SE

Technical data sheet

The Rotavapor® R-220 SE is designed to fulfill a wide range of distillation applications in the industrial environment. Safety, robustness and easy handling are the key benefits of this system. Seven different glass configurations and a wide range of accessories guarantees the perfect setup for maximum performance.



Overview

The Rotavapor® R-220 SE is available in different versions and configurations to cover a broad range of applications. The following table provides a rough overview of the available versions.

	R-220 SE Basic	R-220 SE	R-220 SE High Performance	R-220 SE Continuous
Including vacuum controller		●	●	●
Continuous distillation				●
High distillation rate (> 16 L Ethanol / h) *			●	
7 different glass configurations		●		

* For a comprehensive comparison of the distillation rates, see section "Performance" on page 8.

A wide range of applications can be performed with the R-220 SE. Nevertheless some versions are specially designed to fulfill specific needs better than others. The following table helps to choose the most suitable version.

Application	R-220 SE Basic	R-220 SE	R-220 SE High Performance	R-220 SE Continuous
For easy distillable or drying products	++	++	+	—
Heat sensitive products	++	++	+	++
Reflux distillations (e.g. Recrystallization)	—	++	—	—
Continuous distillation (fully automated filling and draining process)	—	—	—	++
Solvent recycling	+	+	++	++
Foaming applications	+	++	+	—

Legend:

++ : Recommended version that is special designed for this application

+ : Possible to perform this application, but not optimized for it.

— : not possible or recommended

Order code

Choose the configuration according to your needs:

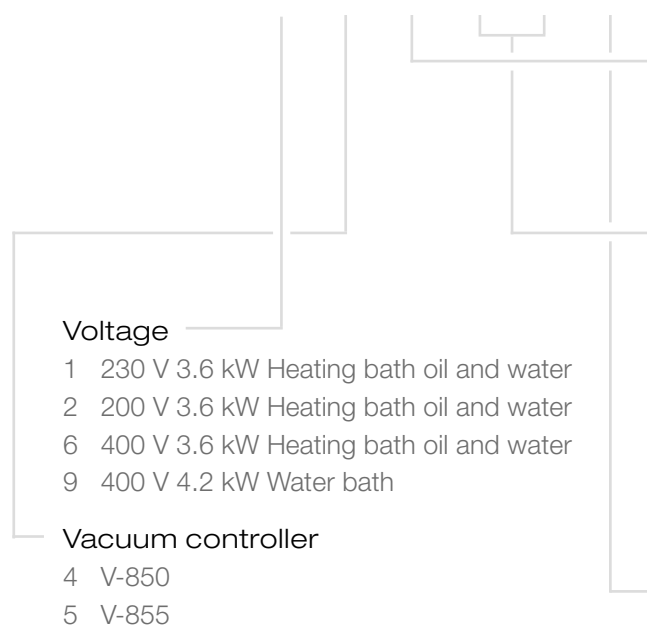

Voltage

- 1 230 V 3.6 kW Heating bath oil and water
- 2 200 V 3.6 kW Heating bath oil and water
- 6 400 V 3.6 kW Heating bath oil and water
- 9 400 V 4.2 kW Water bath

Vacuum controller

- 4 V-850
- 5 V-855

Evaporating flask

- B Evaporating flask, 10 L
- C Evaporating flask, 20 L
- X Without evaporating flask

Condensation unit

- 21 Reflux, R
- 22 Reflux Bullfrog, RB
- 23 Cold trap, C
- 24 Descending, D
- 25 Descending Bullfrog, DB
- 26 Descending with secondary condenser, D2
- 27 Descending Bullfrog with secondary, DB2 condenser

Collection unit

- 1 Single receiving flask, 10 L
- 2 Dual receiving flasks, 2 x 10 L



R-220 SE Continuous version

- 1 Version 230 V 3.6 kW Heating bath oil and water
- 2 Version 200 V 3.6 kW Heating bath oil and water
- 6 Version 400 V 3.6 kW Heating bath oil and water
- 9 Version 400 V 4.2 kW Water bath



R-220 SE High Performance version 400 V with Vacuum Controller V-850

Scope of delivery

All Rotavapor® R-220 SE models are delivered ready to use, including all needed tools and are complete of:

Components	R-220 SE
Glass configuration according to order configuration	1
Evaporating flask according to order configuration	1
All needed tubing's (vacuum and cooling)	1
Feed tubing, PTFE, 8/10 mm, 2 m	1
Seal removing tool	1
Operation manual	1
Feed hose (PTFE), 3 m	1

Components	R-220 SE
Seal removal tool	1
Operation manual	1

Technical data

Dimension

Maximum dimensions (WxDxH)	1200 x 560 x 1800 mm
----------------------------	----------------------

Electrical

Voltage	200 V (1Ph, N, G) 230 V (1Ph, N, G) 400 V (3Ph, N, G) R-220 SE High Performance is only available for 400 V (3Ph, N and G)
Frequency	50 – 60 Hz
Power consumption	4900 W (standard heater) 5500 W (4200 W heater) 6500 W High Performance version

Standards

UL / CSA	Yes
CE marking	Yes

Safety

Safety coated glassware	Yes, except the evaporating flask
Over temperature protection of the bath	Separate monitoring circuit with manual reset Error if temperature is 15 °C above set value
Rotation	Soft start Stop in case of blocked rotation
At any error	Bath lowering, heater off, rotation off Type of error showed on display Reset with main switch

Rotation

Motor	1-phase; 0.6 A at 50 Hz; 10 Nm
Controlling	Electronically
Speed	5 – 150 rpm
Accuracy	+/- 1 rpm at 5 rpm to +/- 5 rpm at 150 rpm

Cooling

Consumption	120 – 200 L/h (adjustable via integrated needle valve)
Restriction	max. 2.7 bar abs. without pulsation

Display

Bath temperature	1 °C steps
Cooling temperature (option)	1 °C steps
Vapor temperature	1 °C steps
Set rotation speed	1 rpm steps
Set bath temperature	1 °C steps
Actual vacuum	1 mbar steps
Set vacuum	1 mbar steps

Heating (bath)

Medium	Water or oil (R-220 SE High Performance version and 4.2 kW heater version, only water)
Temperature range	Ambient to 180 °C
Heating capacity	230 V 3600 W (3 W/cm ²) 400 V 3600 W (3 W/cm ²) or 4200 W (only for water), or 6300 W (only for water)
Accuracy	+/- 2 °C

Materials

Housing	Stainless steel 1.4301 (AISI 304)
Gear head	Aluminum cast (3.2373)
Painting	Powder coated with Epoxy (EPX)
Bath pan	Stainless steel 1.4404 (AISI 316 L)
Heating element	Stainless steel 1.4404 (AISI 316 L)
Glass	Borosilicate 3.3
In contact with product	FDA approved materials
Leakage of the complete system	<1 mbar/min

Sensors

Vapor temperature	PT-1000, 2 wire
Bath temperature	PT-1000, 2 wire
Speed sensor	Hall-sensor
Vacuum	Ceramic , capacitive

Accessories

	Order number
Vacuum Pump V-710 Speed controlled with 3.1 m ³ /h and ultimate vacuum of 2 mbar	11056610
Vacuum Pump V-710 including secondary condenser Speed controlled with 3.1 m ³ /h and ultimate vacuum of 2 mbar. Including secondary condenser	11056611
Trolley Stainless steel trolley with extra space for Vacuum Pump V-710. Not necessary if utilizing the Recirculating Chiller F-125	041257
Recirculating Chiller F-125 Recirculating chiller with a cooling capacity of 2500 W at 15 °C. This chiller is not only cooling the Rotavapor® R-220 SE but also operates as a trolley and host of the Vacuum Pump V-710.	11056468
Manual flask handler for 20 L flask For easy mounting and removal of the flasks along with safe transport.	041400
Foam detector assembly Internal sensor detects rising foam and triggers a short aeration pulse, eliminating foam. Only in combination with a descending glass assembly	11056083
Vacuum valve, 4 mm, 24 V, connection piece 12.5 mm Electrical valve for vacuum regulation when operated with a non-BUCHI vacuum pump.	11055928
Vapor duct with integrated sinter plate The integrated sinter plate P3 protects the condenser assembly against powder and dust during the drying process.	041100
Cooling water flow sensor Checks the flow of coolant, stopping operation when flow of coolant is insufficient or interrupted.	11055971
Cooling water temperature sensor Needed to display the coolant temperature for optimal distillation settings.	11055988
Cooling water valve Eliminates unnecessary water waste by stopping cooling water flow when not in use.	041191
Level sensor for receiving flask For defined concentration of product or to prevent an overflow of the secondary condenser if combined with a Vacuum Pump V-710 with secondary condenser	11056192
USB module, incl. USB flash drive Saves parameters from application runs on a USB flash drive for data transfer.	11056175
Stopper, PE, 120 mm To close the evaporating flask.	11057349
Flange adapter for flasks , SJ29.2/32 To use a 1, 2 or 3 L evaporating flask with SJ29.2/32	11058738
IQ / OQ Rotavapor® R-220 SE	11057172

Safety devices	Order no.	Picture
Standard safety shield Safety shield for the following glass assemblies, with one receiving flask: D, D2, R, C	11055796	①
Standard safety shield, two flasks Safety shield for the following glass assemblies, with two receiving flask: D, D2, R, C	11055797	②
Safety shield, Bullfrog Safety shield for the following glass assemblies, with one receiving flask: DB, DB2, RB	11055798	③
Safety shield, Bullfrog, two flasks Safety shield for the following glass assemblies, with two receiving flask: DB, DB2, RB	11055799	④
Bath shield cpl. Separate bath shield complete	11055364	⑤
Protective grid cpl. Protects the glass assembly and the bath against falling objects (only in conjunction with corresponding safety shield)	11056081	⑥
Bullbar cpl. Reinforced steel tube frame	11056082	⑦

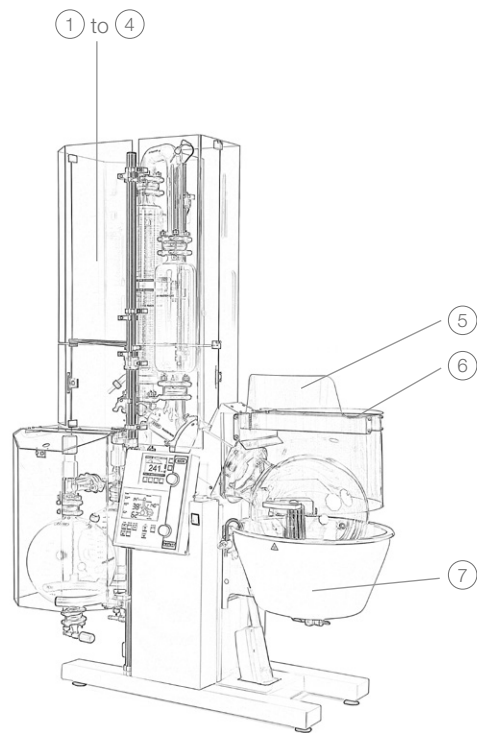

Performance

The following chart shows the maximum distillation rate of the different R-220 SE versions

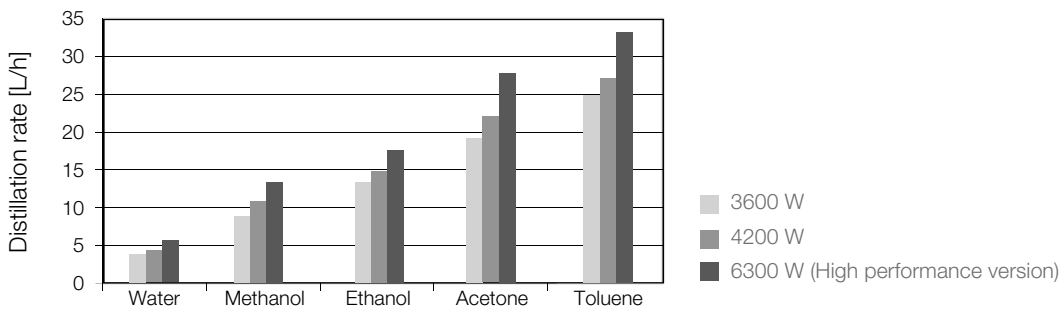

The maximum achievable distillation rate depends is not just related to the heating capacity, but also on rotation speed, flask size and temperature difference between bath and cooling.

To get a high distillation rate:

- set a high rotation speed
- choose a large evaporating flask (20 L)
- set a high temperature difference between bath and cooling

Functional principle - continuous distillation

The continuous version of the Rotavapor® R-220 SE is based on the descending glass assembly. Four valves and three sensors are controlling the distillation process. This allows distillations of large volumes almost unattended.

This version is particularly suitable for solvent recycling or concentrations in industrial preparative chromatography.

The system controls the followings functions:

- Automatically empties the receiving flask when full.
- Simultaneously refills the evaporation flask.
- Monitors fill levels in both the evaporating and receiving flasks.
- Controls valves for filling and draining.
- Safety shut down in case of flooding the system, empty product tank or blocked drain.

